

PLUS

Copyboard with Memory Function

M-10S/M-10W

User's Manual

Thank you for your purchase of the PLUS Copyboard.
Please read this User's Manual carefully before use to take full advantage of the functions of this product. After you have finished reading the manual, please keep it for future reference.

**This User's Manual covers both models M-10S and M-10W.
The copyboard is available in a standard size (model M-10S) and a wide size (model M-10W).
A printer and stand may be available as options depending on the product you purchase.
Descriptions and diagrams refer to model M-10S.
* Model names will be given where model-specific functions or operations are concerned.**

Trademarks

- Microsoft and Windows are trademarks or registered trademarks of the Microsoft Corporation.
- HP and HP Deskjet are trademarks or registered trademarks of the Hewlett-Packard Company.
- CompactFlash and CF are trademarks of SanDisk.

The trademarks of the various companies and the product trademarks, even when not written down, will be given due respect. Product names and company names appearing in this manual are registered trademarks or trademarks of the respective companies.

- (1) The contents of this manual may not be reprinted in part or whole without permission.
- (2) The contents of this manual are subject to change without notice.
- (3) Great care has been taken in the creation of this manual; however, should any questionable points, errors, or omissions be apparent, please contact us.
- (4) Notwithstanding Section (3), this company will not be responsible for any claims of loss or profit or other matters deemed to be the result of using this unit.
- (5) The use of a printer as the peripheral device of the PLUS Copyboard is taken to be a prerequisite; therefore, operation will not be guaranteed when the Copyboard is used with a direct connection to a personal computer.
- (6) Manuals with incorrect collating or missing pages will be replaced.

TABLE OF CONTENTS

Features E-4

Safety Precautions

 Warnings and Precautions E-5

 Care and Cleaning E-6

Package Contents E-7

Names of the Parts E-8

 Copyboard Front E-8

 Copyboard Rear E-9

 Copyboard Control Panel E-10

Operation Steps E-11

Printing E-12

 Basic Printing Operation E-12

 Selecting the Print Density E-12

 Making Additional Prints E-13

 Cancellation of the Print Operation in Progress E-14

 Moving the Sheet Surface Manually E-14

Using CompactFlash Cards

 Memory Storage Procedure E-15

 Examples of Playback of CompactFlash Cards with a Personal Computer E-17

 Deleting All of the Memory Card Data with the Copyboard E-18

Printer Operation Guide

 Printer Set Up E-19

Meaning of Error Displays E-20

Troubleshooting E-21

Specifications E-22

Appendix

 Connections between the Copyboard and Printer E-23

 Changing the Height of the unit E-24

Meaning of the Terms Used in this Manual

- The term “printing” refers to printing with a printer, “memory storage” refers to storage on a CompactFlash card, and “copy” refers to both printing and memory storage.
- A CompactFlash Card may be abbreviated as a “memory card” (or CF card).
- A temporary storage location for read data is termed “internal memory”.
- The portion on which drawings are made is termed the “sheet surface”.
- Feeding of the sheet is termed “scrolling” or “moving”.

FEATURES



Functional and Stylish

The M-10 appears in a new, stylish design.

The operation controls such as control panel, memory card slot, printer, and other parts have all been positioned at the right side to make ease of use consistent with the clear-cut design.

The height of the copyboard can be adjusted 3 levels above and below the standard position.

In comparison with our series of products up until now (i.e., the BF-040 Series), the weight of the copyboard is about 10 kg lighter which makes a wall mounted installation easy.



4-Color or Black & White Print with One Button

A press of the "COPY" button on the control panel of the copyboard permits a printout of whatever has been drawn on the copyboard surface. A printer can be combined with the copyboard to suit the application or needs of the meeting room and provide either 4 colors for easy viewing or economic and speedy monochrome.



Plain paper for easy to be Written on and Stored

The printer for the M-10 supports the use of regular paper. The printed paper can be written on directly and stamps can also be applied so that the paper may be kept as a record of the meeting and may also be circulated conveniently. The printer can print up to 20 sheets of the same item in one session.



One Button Stores the Board Contents in Memory

A press of the "MEMORY" button on the control panel of the copyboard permits the written board surface to be stored in memory as is. This feature is cableless and there is no need for troublesome connection work.



Personal Computers Can also Be Incorporated Simply

The memory card data can be incorporated simply, either using the card by itself, or via an optional adapter. Simple connection can be made through a reader that supports USB for desktop computers, or with a PC card adapter in the case of notebook computers. Portability is afforded even at your outside destination since the data can be carried with you.



Simple Playback with an Internet Browser, and Easy Pasting to E-mail

Memory card data is in the PNG format, the international image format. Browser support is for Internet Explorer 4.0 or later or Netscape Communication 4.04 or later. A double click permits display without being aware of the software and the allows for easy pasting to the e-mail to the meeting participants as well as placement on the home page for the intranet. Sharing and storage are possible without fuss even at remote locations.



Density Adjustment

A density selection function offers distinct copies even for pale writing.

IMPORTANT SAFETY INFORMATION



WARNING

The unit's rear panel should never be opened by anyone other than a qualified serviceperson. There are many high voltage parts inside the unit, and touching them is dangerous. For replacement of the light source's fluorescent bulb, internal inspections, adjustments, repairs or internal cleaning, please contact your store of purchase.



CAUTION

Continued use of the unit under abnormal conditions (when the unit is emitting smoke, unusual odors or sounds) could lead to fire or electric shocks.

If an abnormal condition should arise, turn off the unit's power, then immediately unplug the power cord from the AC outlet.

Check that no more smoke, etc., is being emitted, then contact a sales outlet for repairs.

Repairing the unit yourself is dangerous. Never attempt to do so.

WARNING

This is a FCC class A product. In a home environment this product may cause radio interference in which case the user may be required to take adequate measures.



This symbol warns the user that uninsulated voltage within the unit may have sufficient magnitude to cause electric shock. Therefore, it is dangerous to make any kind of contact with any part inside of this unit.



This symbol alerts the user that important literature concerning the operation and maintenance of this unit has been included. Therefore, it should be read carefully in order to avoid any problems.



SAFETY PRECAUTIONS

Heeding the safety precautions below will lengthen the product's service life and prevent fires, electric shocks and injury. Read these safety precautions carefully and be sure to heed them.

Power Supply

- Using at other than rated voltage could result in fire or electric shock.

Handling the Power Cord

- Damaging the power cord could lead to fire or electric shock.
 - * When installing, do not squeeze the power cord between the product and a wall, rack, etc.
 - * Do not modify or damage the power cord.
 - * Do not place heavy objects on the power cord or pull strongly on it.
 - * Do not place the power cord near heating appliances or otherwise heat it.
 - * When unplugging the power cord, always do so by pulling on the plug, not the cord.
- If the power cord should be damaged, ask your store of purchase to replace it.
- If there is dust or metal objects on or near the power plug's blades, unplug the power cord then wipe the blade area clean using a dry cloth. Continued use without cleaning the plug could lead to fire or electric shock.
- Do not plug in or unplug the power cord with wet hands. Doing so could lead to electric shock.
- When moving the unit, turn off the power and be sure to unplug the power cord from the AC outlet first. Moving the unit with the power cord plugged in could damage the cord, leading to fire or electric shock.
- Connect the power plug securely to the AC outlet, pressing the blades in to the hilt. Uncomplete plugging could cause heating or attract dust, leading to fire. In addition, touching the plug's blades could cause electric shock.

CARE AND CLEANING

Installation

- For stand type units, be sure to lock the casters.
- When mounting on a wall, be sure to check first that the wall surface is strong enough to support the total weight of the main unit, mount fittings and printer over a long period of time (including during earthquakes). If the wall is not strong enough, reinforce it before mounting the unit.
- Getting water on or inside the unit etc., could lead to fire or electric shock. Be particularly careful when using the unit near a window when it is raining or snowing and when using it near the shore of the ocean and lakes.
- Do not set the unit in hot places exposed to direct sunlight or in places exposed to wind coming directly from an air conditioner.
Do not set the unit in places exposed to soot or humidity (on kitchen counters, near humidifiers, etc.).

Preventing Tipping (for stand type units)

To prevent tipping, heed the instructions below. Tipping could lead to personal injury or damage the unit.

- Place the unit on a flat floor.
- Lock the casters when using the unit. When moving it, be sure to unlock the casters to prevent tipping.
- Do not lean against the unit or apply excess force to the top of the unit.

Cautions on Usage

- Take care that the unit does not get wet and that water does not get inside. Do not place objects containing chemicals, water or other liquids (vases, potted plants, glasses, cosmetics, etc.) on top of the unit. The liquid could spill and get inside the unit, leading to fire or electric shock.
- When lifting the unit to adjust the height, etc., the unit should be lifted by at least two persons to prevent it from tipping and causing personal injury.
- Do not move the sheet with paper or other objects attached to it. Doing so could cause damage.
- Do not wipe the unit or sheet with thinner, benzene, alcohol or other such products. Doing so could cause discoloration or damage the sheet.
- Only use markers designed exclusively for this product.
Using other markers could damage the sheet. Also note that it may not be possible to erase the ink of other markers.
- When moving a stand type unit, be sure to unlock the casters, then support the unit from both sides and move it gently and carefully to avoid shocks.
- When not using the unit for long periods of time, unplug the power cord from the AC outlet for safety.

Cleaning

- If the sheet is dirty, wipe it clean using a damp, thoroughly wrung out cloth. For tough dirt, apply some diluted neutral detergent to a cloth, wipe off the dirt, then wipe again to remove any detergent.
Wait until the sheet is completely dry before using it.
- Wipe of any marks from markers on the dust tray or the plastic frame using a damp, thoroughly wrung out cloth.
For cleaning of the printer, please refer to the printer's operating instructions.

PACKAGE CONTENTS

The package contents are as described below. Please check before use.

Copyboard, main unit 1

See "Assembly and Setup Manual" for information about the assembly parts of the copyboard.

Printer* 1

Please see the instruction manual of the printer for information about the printer accessories.

Stand* 1

*The printer and stand may be sold separately.

■ Copyboard Accessories

- **Special markers**
(One each of black, red, blue, and green)
Use these markers to draw on the sheet surface.

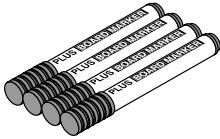

- **Special eraser (1)**
Use this to erase the drawing.

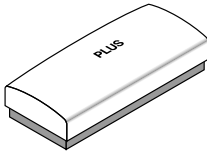

- **Power cable (4 m)**
This cable supplies power to the copyboard.

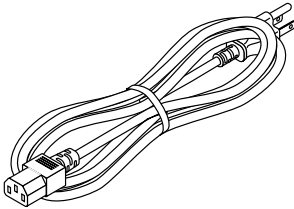

- **Cushions (2 pcs.)**
These cushions are used to absorb the shake of printer tray in case wall mounting.

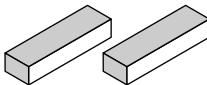

- **Printer tray (1 set)**
The printer is placed on this tray.
(The set includes one printer tray, left and right brackets, six M3 assembly screws, four M4 screws, and three cable clips.)

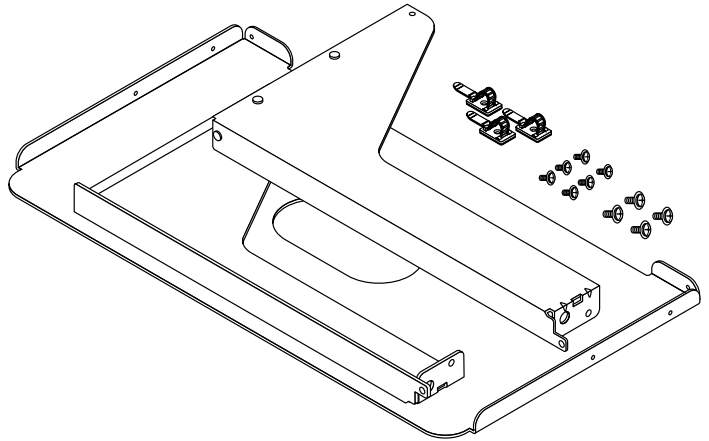

- **USB cable (1 m)**
This cable is used to connect the dedicated printer with the printer output connector of the copyboard.

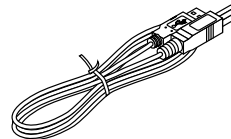

- **Wall mount brackets (1 set)**
These fittings are used to mount the copyboard on a wall.
(The set includes four copyboard brackets and 16 M4 mounting screws.)

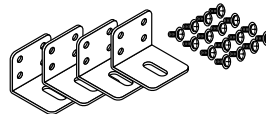

Documents

- **User's manual**
Includes information about safety precautions and the use of the copyboard.
- **Assembly and Setup Manual**
Information covers the setup of the copyboard and the connections with the printer.

NAMES OF THE PARTS

Copyboard Front

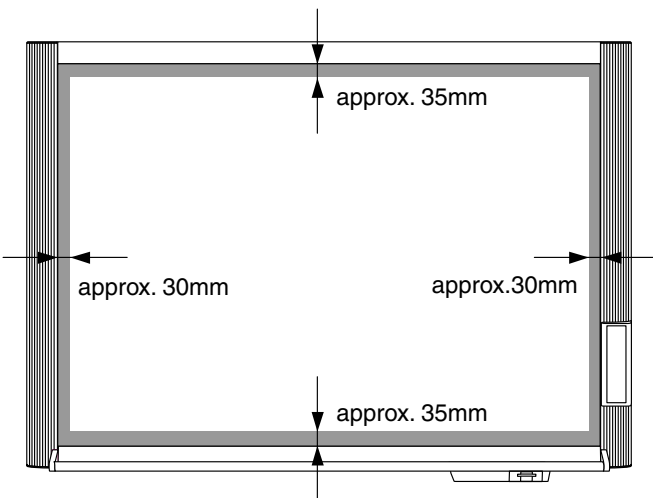
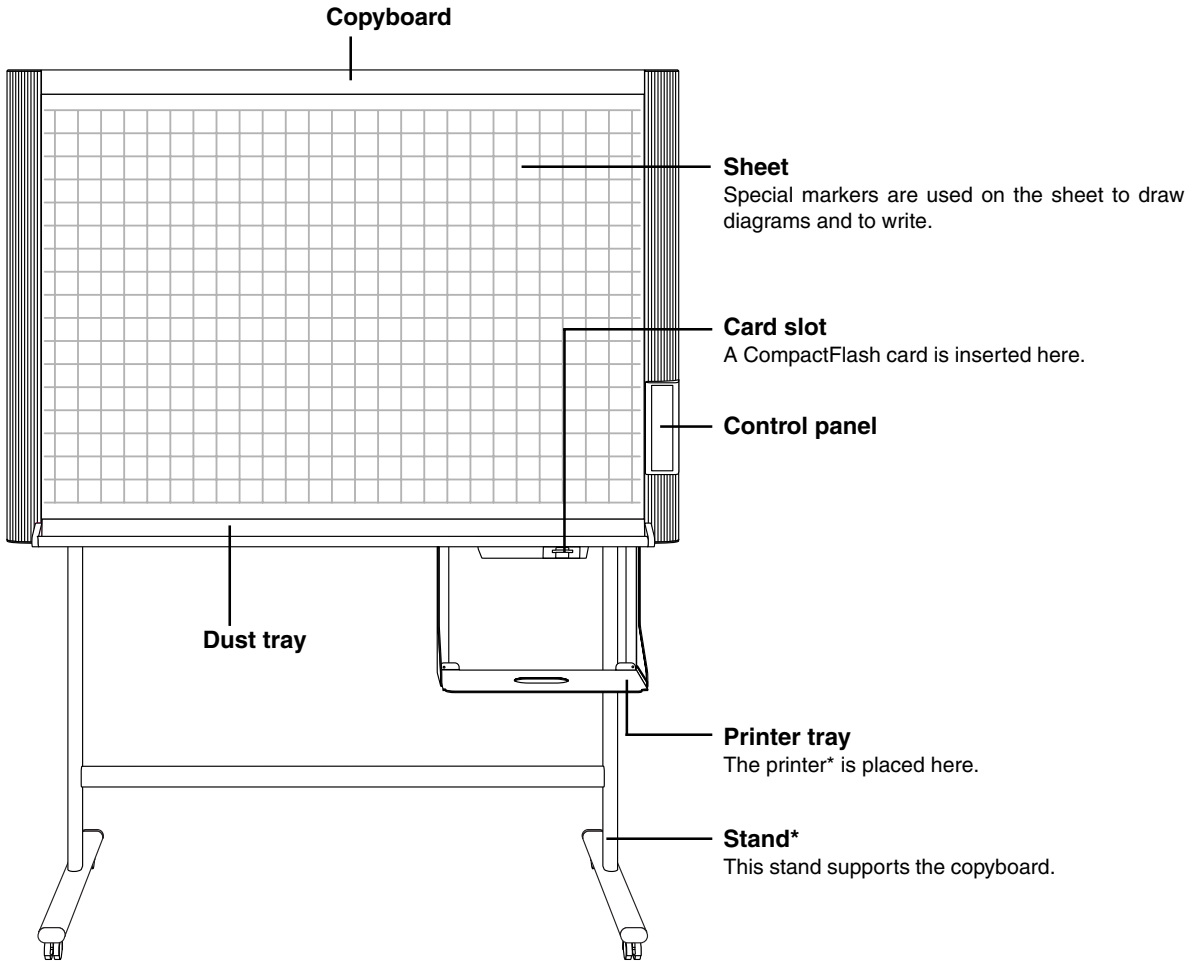

Effective reading size

The copyboard cannot read the indicated border portion of the sheet surface when copying. Please write within the effective reading area.

Note

The vertical readable area of the Copyboard is the portion between the most upper ruled line and the most lower one on the sheet.

*The printer and stand may be sold separately.

Copyboard Rear

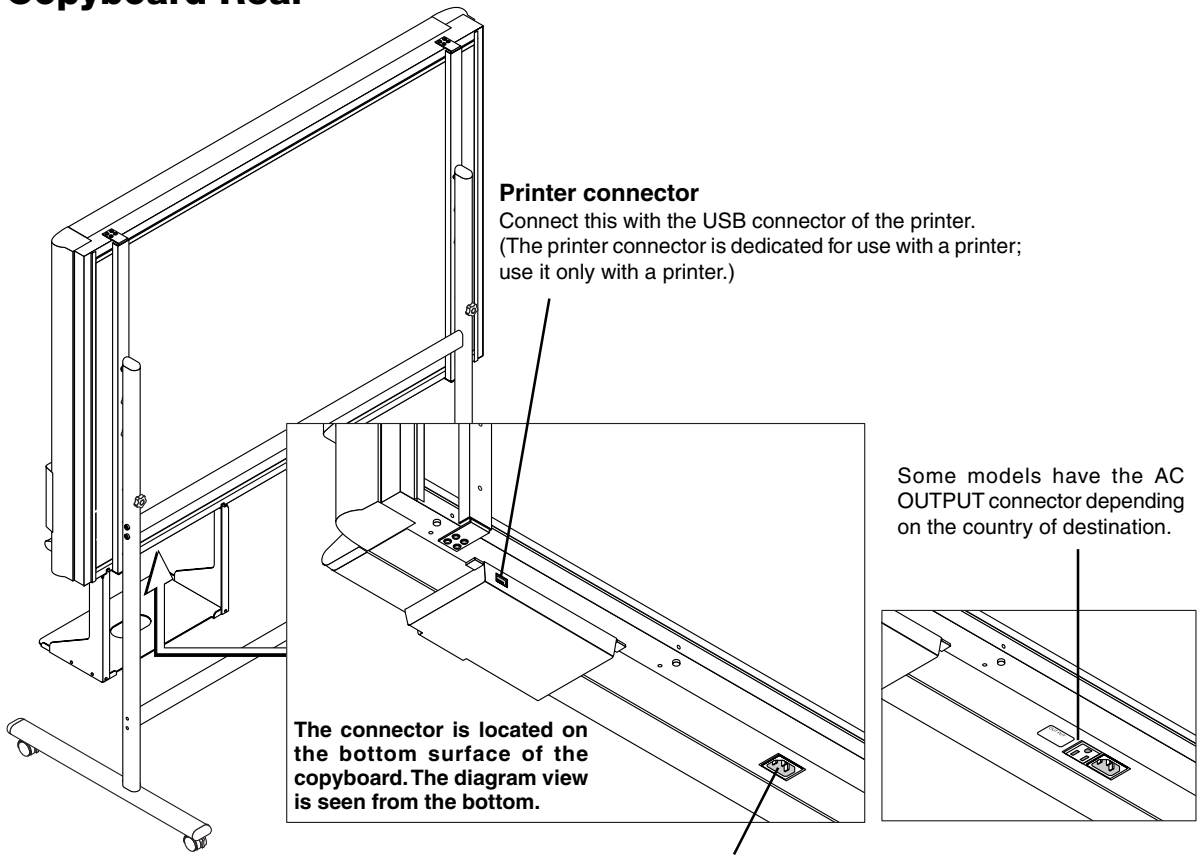

Printer connector

Connect this with the USB connector of the printer.
(The printer connector is dedicated for use with a printer; use it only with a printer.)

Some models have the AC OUTPUT connector depending on the country of destination.

AC input connector

This connector supplies power to the copyboard. Make a connection between this and an AC wall power outlet.

Note

Please take the printer power directly from a wall outlet.

Locking and unlocking the stand* casters

After setup, please lock the casters with the stoppers. Unlock the caster stoppers when moving the copyboard. Lock the caster by pressing the bottom part of the lock button. Unlock by pressing the top part.

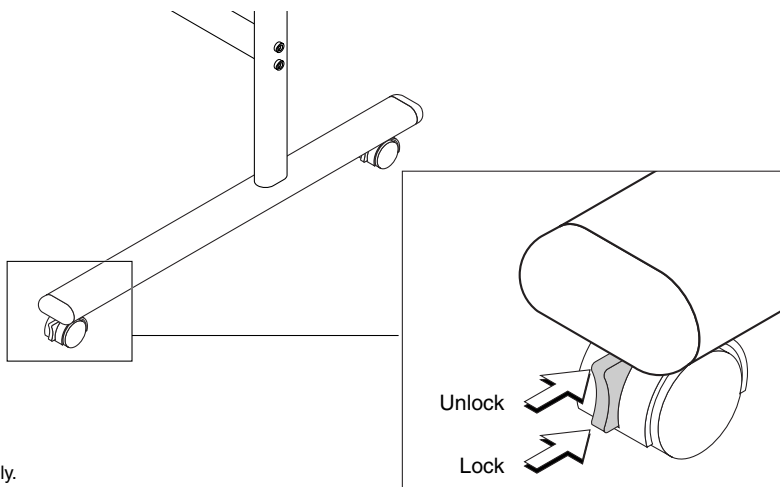

* May be sold separately.

Copyboard Control Panel

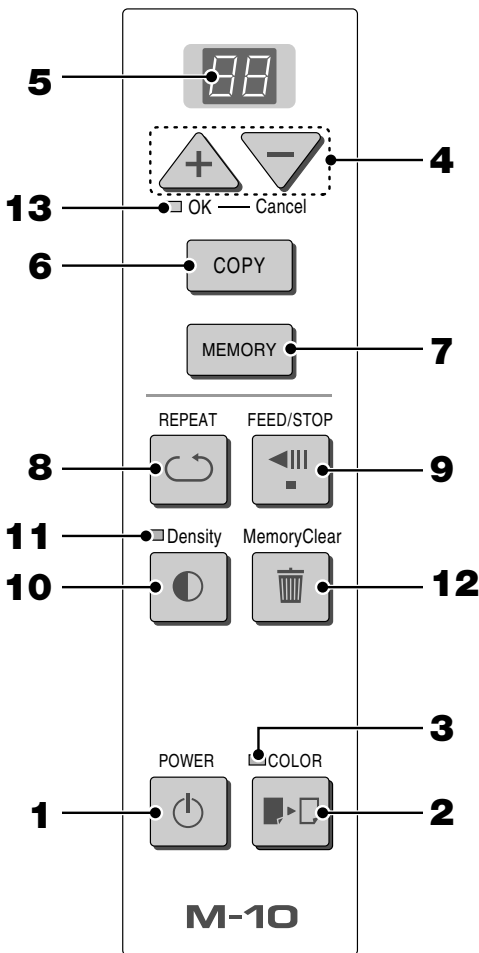

When pressing a button, please press the center area (i.e., the round and protruding portion). Pressing the corner will not work.

1 POWER button

Switches the power of the copyboard on and off.

Note

The Power button does not synchronize with the main power control of the Copyboard.

2 COLOR button

Selects whether to print (or store in memory) in "color" or "black & white".

The COLOR lamp lights when "color" is selected.

3 COLOR (mode) lamp

Lights in green when "color" is selected with the COLOR button.

4 + / - buttons (Number of copies)

Pressing the + button or the - button sets the number of copies to be printed (to a maximum of 20 sheets). The number of copies appears in the display window.

5 Display window

This 7-segment LED displays the number of copies to be printed, the memory storage operating condition, and error information. Please see Page E-21 for details about error information.

6 COPY button (Print)

Moves a one-screen portion of sheet and reads it, then prints the number of copies displayed in the display window.

7 MEMORY button (Memory storage)

Moves a one-screen portion of sheet and reads it, then stores the data on a CompactFlash card.

8 REPEAT button

Prints the previously printed sheet surface one more time. (The sheet does not move.)

The number of copies can be changed, but the density and the color/monochrome selection cannot be changed.

9 FEED/STOP button

Scrolls the sheet one screen portion left, then stops automatically. A press of this button while scrolling will stop the scrolling.

10 Density button (Copy density)

Selects the printing density, either "standard" or "dark". The Density lamp lights when "dark" is selected.

11 Density (mode) lamp

Lights in green when "dark" is selected with the Density button.

12 MemoryClear button

(Total erasure of CompactFlash card)

A press of the MemoryClear button causes the Clear mode lamp to flash. (The display window indicates "99 (max.)" number of files in a flashing display.)

A press of the OK (+) button erases all the data in the PVW folder of the CompactFlash card.

To avoid erasure, press the "Cancel" (-) button. The display window returns to display the number of print copies. Please see Page E-19 for details.

13 Clear (mode) lamp

The lamp lights in orange to indicate that the MemoryClear button has been pressed and the unit is in the erasure mode.

OPERATION STEPS

The copyboard uses a CCD image sensor to read the diagrams and writing made with the special (four color) markers and prints this at reduced size with a printer that is connected to the copyboard. A press of the COPY button or MEMORY button scrolls the surface and reads it, accumulating the image data in internal memory. A press of the COPY button outputs the image data to the printer, whereas a press of the MEMORY button outputs the data to a memory card.

*** Please assemble your newly purchased copyboard and connect the printer.**

See "Assembly and Setup Manual" on separate sheets.

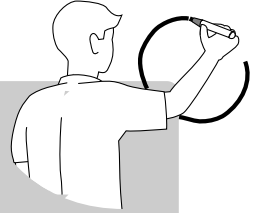

Draw on the Sheet Surface

Please draw with the special markers that have been supplied. To erase, use the supplied special eraser. Please be sure to draw with the special markers. Failure to do so may result in a drawing that cannot be erased or soiling of the sheet. To move the sheet by hand, please see "Moving the Sheet Surface Manually" on Page E-14.

Making Copies

- (1) Set A4 or letter size paper.
- (2) Switch on the printer power.
See "Printer Operation Guide" on Page E-19.
- (3) Press the Power button of the copyboard and switch on the power. (black & white will be set when the power is switched on.)
- (4) To make copies in color, press the COLOR button to light the COLOR lamp.
- (5) Press the COPY button. The copyboard will move a one-screen portion of sheet, read the image, and start the copy operation*.
See "Printing" on Page E-12.

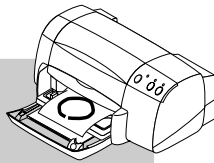

Storing Images on Memory Cards

- (1) Press the Power button of the copyboard and switch on the power. (black & white will be set when the power is switched on.)
- (2) To store the image in color, press the COLOR button to light the COLOR lamp.
- (3) Insert a memory card into the card slot of the copyboard.
- (4) Press the MEMORY button*.
See "Using CompactFlash Cards" on Page E-15.



When Not Using the Copyboard

- (1) By all means, cleanly erase the drawing from the sheet surface with the special eraser. (Leaving the drawing for a long period will make it harder to erase.)
- (2) Press the POWER button of the copyboard and switch off the power.
- (3) Switch off the printer power.

* A press of the MEMORY button while printing is in progress will store the image in memory after printing is completed. Likewise, a press of the COPY button while the memory storage operation is in progress will start the printing operation after memory storage is completed. This convenience allows both printing and memory storage to be performed with a single image reading.

Note

- When printing or memory storage are performed in color, the colors may vary somewhat from those of the markers.
- Blurred characters, thin lines, overlapping of markers and other factors can cause colors to differ in places and can also result in portions that cannot be scanned successfully. When "Density" is set to "Deep", the overall print may be dark and the ruled line may appear on the copy. In the case of the combination of Deep and Color Mode, the black ink may be mixed into other color.
- To obtain a stable image, please wait 5 minutes after switching on the fluorescent lamp and then perform printing or memory storage. The waiting time depends on the room temperature, and may vary a little.
- The built-in memory accumulates the read data that was previously printed or stored in memory. This data is erased when the power is switched off with the POWER button.

Power save function

- If no button is operated for about 30 minutes, the internal fluorescent bulb automatically turns off and the power saving mode is set. (The display on the display window remains lit.)
When "Copy" or "Memory" button is pressed, the fluorescent bulb turns back on and the Copyboard returns to the normal mode.

PRINTING

This function prints the sheet screen of the copyboard on the printer connected to the copyboard.

BASIC PRINTING OPERATION

Preparation:

1. Set A4 or letter size paper in the printer. See Page E-19.
2. Switch on the printer power. See Page E-19.

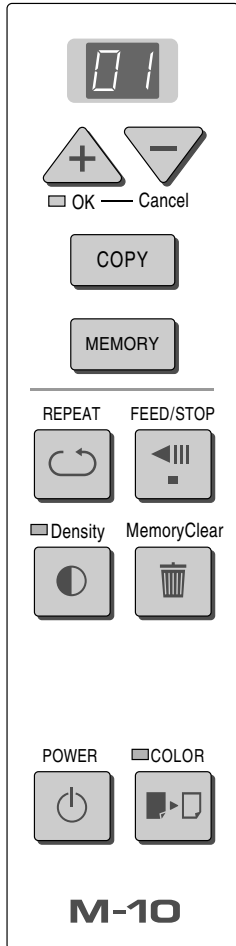

- 1 Press the POWER button and switch on the power.**

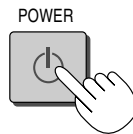

- 2 When the drawing is on the rear sheet, press the FEED/STOP button to bring out the desired surface for printing.**



A press of the FEED/STOP button scrolls the sheet surface one screen portion left and automatically stops it. (The M-10S takes approximately 15 seconds and the M-10W takes approximately 20 seconds.) To stop the operation part way through, press the FEED/STOP button again.

Note

- * The one-screen that is visible is printable position.
- * To make fine adjustments to the sheet surface, when the sheet is stopped, move the sheet slowly by hand. The sheet can be moved either left or right.
- * The peripheral area of the sheet surface is not printed. Please see "Effective reading size" on Page E-8.

- 3 Press the COLOR button and select Color or Black & White.**

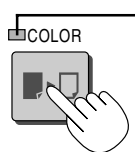

COLOR lamp
Lit Printing will be in color.
Unlit Printing will be in black & white.

- At first, when the power is switched on, black & white is selected.

Note

If a black and white printer is connected, the selection is ignored and printing is performed in black and white.

Continued on next page

4 Press the + button or the - button and select the number of copies.

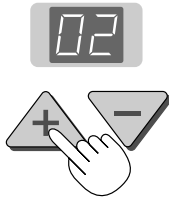

- When the power is switched on, one copy is selected.
- A maximum of 20 copies can be set and the number of copies is displayed in the display window.
- Each press of the + button increases the number of copies (by one) and each press of the - button decreases the number of copies. Press and hold the button to switch continuously.

5 Press the COPY button to print.



- The reading operation is performed for a one-sheet portion (while the sheet is scrolled) and printing starts after the scrolling completes.

Note

- A press of the FEED/STOP button during the reading operation will cause the printing to stop and will result in a partial print. To move the sheet surface, please press the FEED/STOP button after the scrolling has stopped.
- When a CompactFlash card has been inserted, a press of the MEMORY button during printing will start the memory storage operation after printing is completed. (See Page E-15.)
- The one-screen portion is reduced to A4 paper size and printed. In the wide type (M-10W) copyboard, the screen will be reduced to about 71% in the horizontal direction.

6 When the copyboard is not going to be used, press the POWER button and switch off the power.

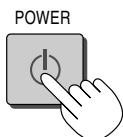

- Switch off the printer power.

Note

- In the absence of button operations, the fluorescent lamp will be switched off after 30 minutes. Another press of the COPY button will start the copy operation after the fluorescent lamp is switched on.

Selecting the printing density

Select this when the density of the print is light.

Press the Density button and select darker or standard.

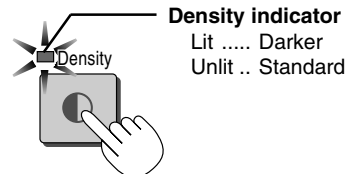

Making additional copies

This will print the copy of the sheet that was scrolled previously one more time.

Press the REPEAT button.

This starts the printing of the image data that has accumulated in internal memory.

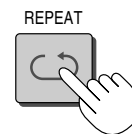

Note

- The sheet is not scrolled when additional copies are made.
- The number of copies can be changed. To do so, make the change before pressing the REPEAT button.
- In repeat printing, the color/black & white and density settings will be the same as those of the prior printing.
- When printing or memory storage has not been performed since switching on the power, image data will not have accumulated in the internal memory and this operation will not be possible.

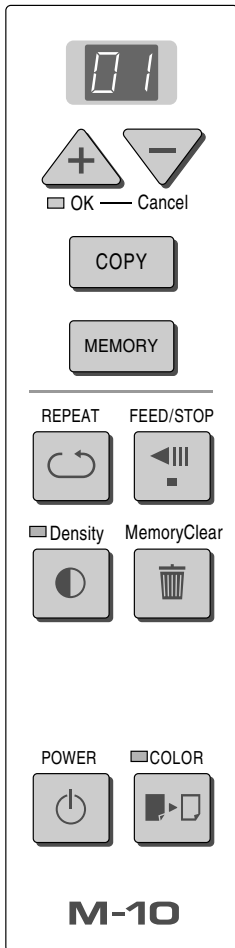

Cancellation of the print operation in progress

During the read operation (when the COPY button was pressed)

A press of the FEED/STOP button will stop the sheet during the reading operation and print the image data that has been read up to then. Please wait until the paper has been ejected from the printer.



Stopping the printing after the COPY button was pressed and the reading completed (While the sheet is stopped)

Stopping the process when multiple copies are being made when making additional copies (When the REPEAT button has been pressed)

Please press the POWER button of the copyboard. Printing will be interrupted in a little while and the paper will be ejected.

Moving the sheet surface manually

The sheet can be moved even when the power of the copyboard is switched off.

The sheet can be moved with your hand either in left or right. Please place your hand at the vertical center and move the sheet slowly. Quick movement can cause damage to the drive mechanism of the copyboard.

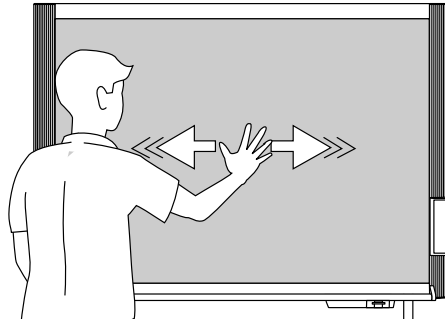

USING COMPACTFLASH CARDS

Use of a CompactFlash card (hereafter abbreviated as a memory card) permits the sheet surface to be stored as image data. The stored data can be read by a personal computer and used to make a meeting record, or can be pasted in a document.

- **Items Required for Using the Memory Function**

- CompactFlash card: TYPE 1 or TYPE 2 (Optional items), or commercially available items. (Please use products bearing the CF  logo.)
- PC card adapter: Optional items or commercially available items
- Personal computer equipped with a PC card slot, or a USB card writer/reader (optional item or commercially available item)

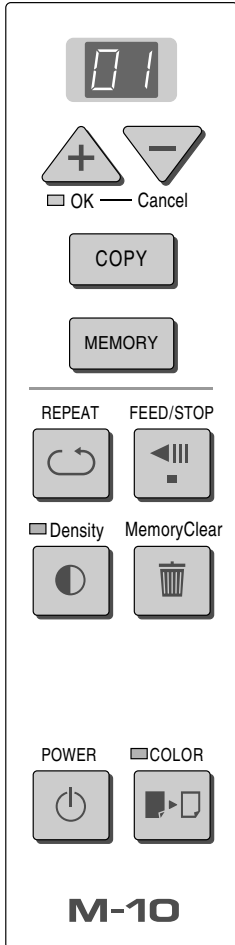

MEMORY STORAGE PROCEDURE

1 Press the POWER button and switch on the power.

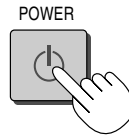

2 Insert the memory card into the card slot of the copyboard.

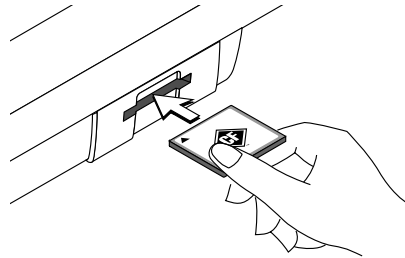

CAUTION

Please slowly insert the memory card keeping it level with face up. The card is designed so that it cannot be inserted backward, but forcing it in will cause damage.

3 When the drawing is on the rear sheet, press the FEED/STOP button to bring out the desired surface for memory storage.



A press of the FEED/STOP button scrolls the sheet surface one screen portion left and automatically stops it. (The M-10S takes approximately 15 seconds and the M-10W takes approximately 20 seconds.) To stop the operation part way through, press the FEED/STOP button again.

Note

- The one-screen portion that is visible is the one that is stored.
- To make fine adjustments to the sheet surface, when the sheet is stopped, move the sheet slowly by hand. The sheet can be moved either left or right.
- The peripheral area of the sheet surface cannot be stored. Please see "Effective reading size" on Page E-8.

CAUTION

CF Card Adapters

Please note that some of CF card adapters may have compatibility issues. Please see our home page for details.

<http://www.plus-vision.com>

Continued on next page

4 Press the COLOR button and select Color or Black & White.

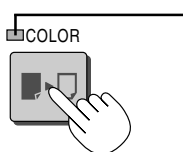

COLOR lamp
Lit Memory storage will be in color.
Unlit Memory storage will be in black & white.

- At first, when the power is switched on, black & white is selected.

5 Press the MEMORY button to store

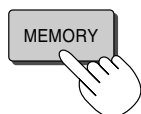

Sequential flashing during memory storage



Display window

- The reading operation is performed for a one-sheet portion (while the sheet is scrolled) and memory storage starts after the scrolling completes.



The (5 second) flashing “CF” display indicates that the memory card has not been inserted. Please insert the memory card and then press the MEMORY button.



The (5 second) flashing “FL” display indicates that the memory card is full. Please see Page E-18.

Note

- For some memory cards, some time may be required for recognition.
- Do not press the FEED/STOP button during the reading operation. Doing so will interrupt the memory storage and only the image data up to that point will be stored.
To change the sheet surface, press the FEED/STOP button after stopping the scrolling.
- A press of the COPY button during memory storage starts the printing after storage is completed.
- In the wide type (M-10W) copyboard, the image will be reduced to about 71% in the horizontal direction.
- Saved files are always dated January 1, 2003.
- If there is not enough space, the memory card is judged to be full from the start. If the memory card runs out of space while a file is being saved, “FL” is displayed at that point. Delete data, set the sheet surface back to the original status, then press the “Memory” button again.

Removal of the Memory Card

Check that the flashing of the display window has changed to a steady light and then pull out the memory card.

CAUTION

- Do not remove the memory card during memory storage (while the display window indication is flashing). Data will be lost if you do so.

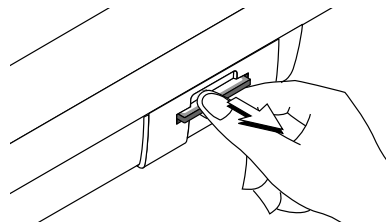

6 When the copyboard is not going to be used, press the POWER button and switch off the power.

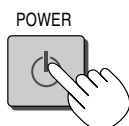

Note

- In the absence of button operations, the fluorescent lamp will be switched off after 30 minutes. Another press of the MEMORY button will start memory storage after the fluorescent lamp is switched on.

EXAMPLES OF PLAYBACK OF COMPACTFLASH CARDS WITH A PERSONAL COMPUTER

This example shows how the data held in the memory card is copied to the hard disk of a personal computer, and deleted from the card.

Methods include the use of Explorer and various other methods.

Please see the instruction manual of your personal computer or the software being used for information about using your personal computer.

The folder name of the memory card is PVW. The image file name inside the folder is MBxxxxxx.png and xxxxxx refers to the 6-digit serial number of the memory storage. (Example: MB000001.png)

Preparation of the Memory Card:

1. Insert the memory card into the PC card adapter.
2. Insert the PC card adapter into the card slot of the personal computer.

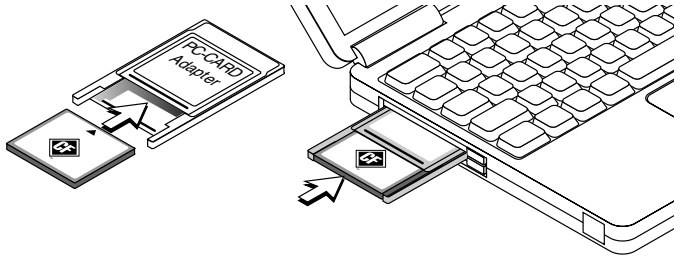

Save the Image Files of the Memory Card in the Personal Computer

1. Open “My Computer” and then open the drive icon which shows memory card.
The folder named “PVW” contains the memory storage data of the copy-board.
2. Store the “PVW” folder in “My Documents” or another location.
All of the data contained in “PVW” will be stored.

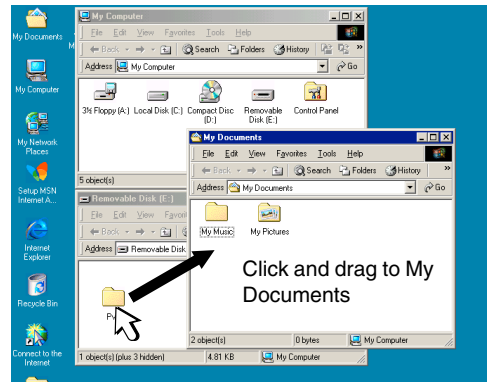

Erasing the Image Files of the Memory Card with the Personal Computer

1. Open “My Computer” and then open the drive icon which shows memory card.
The folder named “PVW” contains the memory storage data of the copy-board.
2. Place the “PVW” folder in the “Recycle Bin”, right click on the icon and select “Empty Recycle Bin” from the pull-down menu.
All of the data contained in “PVW” will be deleted.

Even when the entire folder is deleted, a new PVW folder will be created automatically when CompactFlash card is used again with the copyboard.

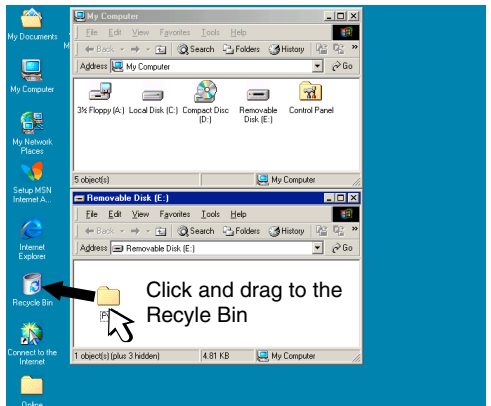

DELETING ALL OF THE MEMORY CARD DATA WITH THE COPYBOARD

When the memory card has become full, copy the required image data on the hard disk of a personal computer or on another medium and then insert the card into the card slot of the copyboard and perform the deleting operation. All of the image data stored in the PVW folder will be deleted.

To delete using a personal computer, please see Page E-17.

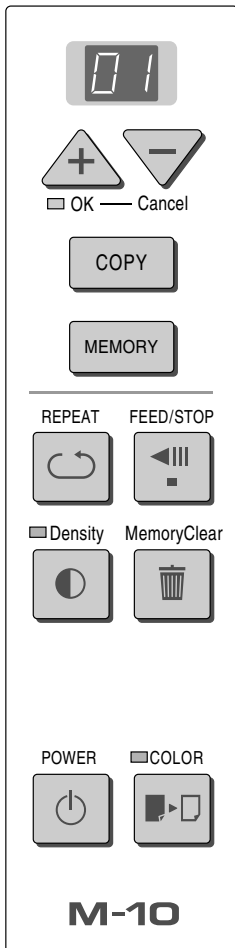

Press the **POWER** button and switch on the power.

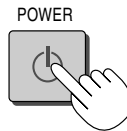

2 Insert the memory card into the card slot of the copyboard.

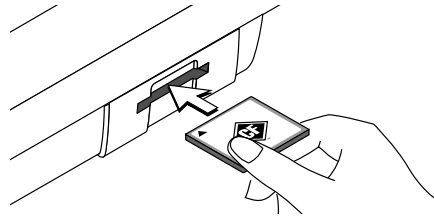

3 Press the **MemoryClear** button.

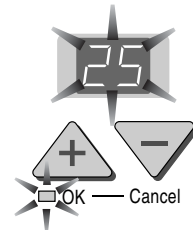

The Clear lamp and the display window will flash. The number in the display window indicates the number of files stored in the PVW folder within the memory card. Note that the maximum indication is 99. (and files in excess of 99 will still appear as 99)

At this time, please make sure that it is all right to erase the image data. To cancel the operation, please press the “-” (Cancel) button.

NOTE

Depending on the number of files stored on the memory card, some time may be required for recognition.

4 Press the “+” (OK) button and erase.

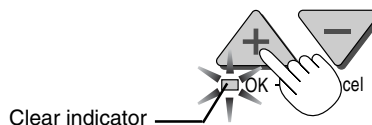

During erasure, “00” will blink in the display window, then will turn on for 3 seconds following erasure and then will return to the number of copies indication.

This completes the full erasure.

CAUTION

Formatting is not possible with the copyboard. Files other data stored with the copyboard or files whose original names have been changed cannot be deleted with this operation. Delete such files using your computer.

PRINTER OPERATION GUIDE

A printer is used to print out the drawn sheet surface.

Depending on the printer, the operation may differ and the names of the parts may be different. Please see your printer instruction manual for details.

PRINTER SET UP

Please check that the copyboard and the printer have been connected. See Page E-23.

1

Set the paper.

Please use A4 or letter size printer paper.
See your printer instruction manual for details.

- 1) Arrange the paper edges so that they are even.
- 2) Insert paper at the specified position of the paper tray.
- 3) Press the paper guide gently until it touches the paper.

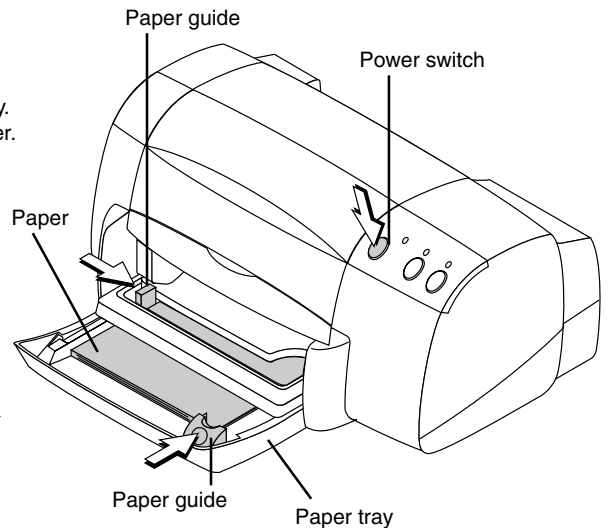

2

Switch on the power.

Press the power switch. The power indicator will light.

This completes the preparation of the printer.

A press of the COPY button on the copyboard operation panel will read the sheet surface portion and start the printing operation.

3

When finished printing...

Switch off the printer power and remove the paper.
Close the paper tray.

Caution: Do not switch off the printer power while printing.

* The printer is an option.

* The diagram shows an example of a printer. Operation and handling may differ depending on your printer.

Precautions in the use of printer paper







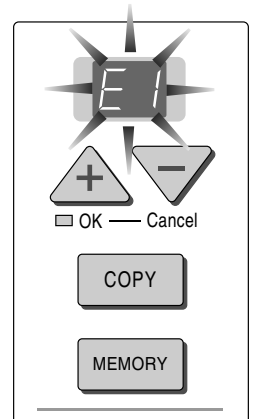

Please observe the following matters to avoid paper feed problems and paper jamming.

- Please do not use thin paper, thick paper, or handmade paper.
 - Do not use paper that has protrusions, recesses, or burrs.
 - Do not use paper that is folded, wrinkled, torn, or has cuts in it.
 - Do not use embossed paper, paper with a rough surface, or coated paper.
 - Do not use paper bearing cellophane tape, seals, or other material.
 - Do not print on paper that has already been printed.
 - Do not insert paper of differing paper sizes.
-

MEANING OF ERROR MESSAGES

If any of the following flashing indications appear in the display window of the control panel, please check the matters described below.
The flashing will continue for 5 seconds.



Error Display Number	Problem and Solution	
 E1 Printer problem	<ul style="list-style-type: none"> Is the printer cable connected? Is power being supplied to the printer? When the printer uses an AC power adapter, is the cable disconnected somewhere? 	<ul style="list-style-type: none"> Connect the printer properly and switch on the printer power.
	<ul style="list-style-type: none"> Has paper been set in the printer? Is the printer error indicator flashing (or lit)? 	<ul style="list-style-type: none"> Insert A4 or Letter size paper into the printer. Read the printer instruction manual.
 E2 Memory card not recognized	<ul style="list-style-type: none"> Is the memory card unformatted. 	<ul style="list-style-type: none"> The copyboard supports the FAT format. Please perform the formatting with a personal computer.
	<ul style="list-style-type: none"> Is a memory card that is not supported by the copyboard being used? When a CF adapter is being used, does the insertion make perfect contact? 	<ul style="list-style-type: none"> Please see our home page for information about memory cards and CF adapters that can be used with the copyboard. (http://www.plus-vision.com)
	<ul style="list-style-type: none"> Is the memory card damaged? 	<ul style="list-style-type: none"> Please check the operation with a personal computer.
 E3 Memory storage problem	<ul style="list-style-type: none"> An error occurred during memory storage. 	<ul style="list-style-type: none"> Please perform memory storage again. Do not insert or remove the memory card during processing.
 E4 Memory clearing problem	<ul style="list-style-type: none"> An error occurred during the memory erasure operation. 	<ul style="list-style-type: none"> Please perform memory clear again. Do not insert or remove the memory card during processing.
 E5 Reading problem	<ul style="list-style-type: none"> The fluorescent lamp is bad or there is a read error. 	<ul style="list-style-type: none"> Press the POWER button to switch off the power, then switch the power on again. Perform the copy operation after this.
 E6 Internal memory problem	<ul style="list-style-type: none"> This is an initialization error of the internal memory when the power plug was inserted into the power outlet. 	<ul style="list-style-type: none"> Unplug the power plug from the power outlet and then plug it in again.
 CF No memory card loaded	<ul style="list-style-type: none"> No memory card is loaded in the copyboard. 	<ul style="list-style-type: none"> Insert a memory card in the card slot.
 FL Memory is full	<ul style="list-style-type: none"> There is no available space. 	<ul style="list-style-type: none"> Please delete unnecessary data using a personal computer or this machine.

If the problem persists, please contact your nearby PLUS Vision sales office, dealer, or store.

TROUBLESHOOTING

Please check the following matters before making a request for servicing.

	Condition	Please Check
CopyBoard Related	Pressing the POWER button does not switch on the power.	<ul style="list-style-type: none"> • Check that the power cable is securely plugged into the power outlet.
	Writing on the sheet is not erased with the eraser.	<ul style="list-style-type: none"> • Was a marker other than a special marker used? (Moisten a cloth with water or neutral detergent, wring well, and wipe carefully.)
	Portions of writing or lines are not printed or stored in memory.	<ul style="list-style-type: none"> • Portions of blurred characters or thin lines may not be printed or stored in memory. • Change Density setting to "Dark". • To obtain a stable image, please wait 5 minutes after switching on the fluorescent lamp and then perform printing or memory storage.
	The copy is soiled.	<ul style="list-style-type: none"> • Is there a lot of marker refuse adhering to the sheet? (When soiled, moisten a soft cloth with water, wring well, and wipe the sheet in a stroking manner.)
	The top and bottom of the copy have a black band.	<ul style="list-style-type: none"> • The fluorescent lamp may be at the end of its life. Please request the replacement of the fluorescent lamp from your dealer.
	The ruled line of the sheet appears on the print or in the file of the memory card, or the black ink mixes into other color in the case of Color Mode.	<ul style="list-style-type: none"> • Check the printing density indicator, and select standard density if the setting is darker.

* If the problem persists, please contact your nearby PLUS Vision sales office, dealer, or store.

Printer Related	A press of the COPY button does not result in printing.	<ul style="list-style-type: none"> • Check that the power cable of the printer and the printer cable are securely connected. • Check that the printer power indicator is lit. • Check that the error indicators of the copyboard and the printer are not lit. • If the error indicator of the copyboard is flashing, please see Page E-20. (Please see the printer instruction manual for information about printer errors.)
	The paper feed is abnormal.	<ul style="list-style-type: none"> • Possible causes include damp paper, overly thin or thick paper, only one sheet of paper is set, and a curved setting of the paper. (Please see the instruction manual for your printer.)
	An altered color is printed, not the specified color.	<ul style="list-style-type: none"> • Please replace the print cartridges with new ones.
	There is no printing.	<ul style="list-style-type: none"> • Check that the print cartridge is properly set. • Check that the print cartridge is not plugged.

* Please see your printer manual for information about printing problems, printer maintenance, and details related to printing.

SPECIFICATIONS

MODEL NAME		M-10S	M-10W
BOARD	Panel Size	920 (H) x 1300 (W) mm	920 (H) x 1800 (W) mm
	Copy Area	850 (H) x 1240 (W) mm	850 (H) x 1740 (W) mm
	Number of Pages	2	
	Paging	Motorized (Forward) & Manual (Forward & Reverse)	
	Grid Line	50 x 50 mm	
	Image Sensor	CCD Optical Sensor	
PRINTER (Optional)	Type of printer	Inkjet (HP PCL Level 3 Compatible) *1	
	Paper	Plain Paper, A4-size/ Letter-size	
	Colors	4-color (Black, Red, Blue, Green) or Black	
	Interface	USB 1.1 equivalent	
MEMORY	Type of Memory Card	CompactFlash Card (CF Card) TYPE I, TYPE II *2	
	File Format	PNG *3	
CONTROL PANEL	Buttons	Power	
		Mode	
		Copy	
		Repeat * 4	
		Memory	
		Feed/Stop	
		Density	
	Memory Card		
	LED Indicators	Color	
		Density	
Clear OK			
Counter Display			
SAFETY STANDARD	Safety Agencies	TUV, CE, UL/cUL, AS *5	
	EMC	CE, FCC, C-Tick Mark *5	
ENVIRONMENTAL CONDITION	Power	100V, 110V, 120V, 220V-240V *5	
	Temperature	10 - 35°C	
	Humidity	30 - 85 % (non-condensing)	
DIMENSIONS	Dimensions (with Stand) *6	1470 (W) x 600 (D) x 1970 [max] (H) mm	1970 (W) x 600 (D) x 1970 [max] (H) mm
	Weight (without Printer)	36 kg	40 kg
MOUNTING		Stand / Wall-mount	
ACCESSORIES		AC Cable for M-10, USB Cable (Printer), Markers (Black, Red, Blue, Green), Eraser, Wall mounting hooks and screws, Operation Manual, Set-up Manual, Paper (10 sheet)	

Remarks

*1: **A Printer is not included in the package.**

*2: A CompactFlash Card is not included in the package.

*3: The PNG format is supported by Microsoft Internet Explorer 4.0 or later, and by Netscape Navigator 4.04 or later.

*4: The maximum repeat is 20 copies.

*5: The condition is subject to change depends on sales area.

*6: The height is adjustable at 1770, 1879 and 1970 mm.

APPENDIX

CONNECTIONS BETWEEN THE COPYBOARD AND PRINTER

The installation method at the printer side will differ depending on your printer.

- (1) Connect the printer connector of the copyboard with the USB connector of the printer using the supplied USB cable.
- (2) Plug the power cable that was supplied with the printer into a wall outlet.
- (3) Connect the AC INPUT connector of the copyboard with a wall power outlet using the power cable supplied with the copyboard.

When connections are completed, fasten the cable with the supplied cable clips.

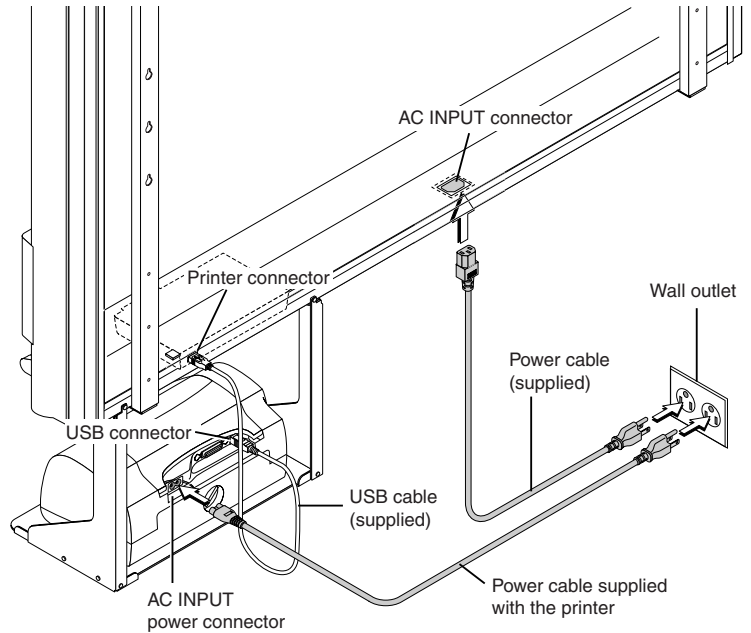

CHANGING THE HEIGHT OF THE UNIT

This is the height adjustment when setting up the copyboard on the optional stand. The stand height can be adjusted to 3 levels in 100 mm units.



CAUTION!

Please have 2 or more persons hold the unit. If the unit is dropped or falls over, this could cause unexpected injury.

Please lock the casters by pushing the lower portion of the lock button.

(1) Disconnect the power cable and all other connection lines.

(2) Take out the printer and remove the printer tray.

Remove the two M4 screws from bottom side of the printer stand and the other two from the rear surface.

(3) Remove the two lock knobs (located at the left and right sides).

(4) Change the hole position of the rear frames.

The copyboard will disengage from the hooks when it is lifted up about 1 cm.

Fully hook the (2 left and right) installation holes of the rear frames onto the hooks of the stand.

If a stay (for preventing shaking) is mounted on the printer stand, insert the stay in its original position.

(5) Attach the lock knobs to the 2 locations (left and right) and tighten to the rear frames.

(6) Return to original by following the steps in reverse.

